

## 5 MHz-1000MHz Broadband Low Noise Amplifier

### Product Features

- Wideband Flat Gain to 1GHz
- Higher Gain: 24 typ.
- Higher linearity: 35dBm @ 500MHz/5dBm 2tone
- SOT-89 package
- -60dBc CSO 135 Channels @ +15dBmV/ch
- -70dBc CTB 135 Channels @ +15dBmV/ch
- -80dBc XMD 135 Channels @ +15dBmV/ch



### Application

- Low Noise Amplifier for CATV, Satellite
- Cable Modem
- FTTH (G-PON, GE-PON)
- Optical node

### Description

OEI Technologies' SG110 is a flat gain, high linearity, low noise, 24dB Gain Block with good OIP3 achieved through the use of 0.5um GaAs Enhancement-mode PHEMT process. SG110 is designed as low cost drive amplifiers for many applications including FTTH , CATV System .

### Specifications

PARAMETER		UNIT	MIN	TYP	MAX	Condition
Frequency		MHz	5		1000	
Gain		dB	-	24	-	30MHz ~ 1000MHz
						5MHz ~ 100MHz
Gain Flatness		dB	-	0.8	-	30MHz ~ 1000MHz
Input Return Loss		dB	-	-12	-	
Output Return Loss		dB	-	-12	-	
Output IP3		dBm	-	35	-	At 500MHz/5dBm 2tone
1dB Compression Point		dBm	-	21	-	At 500MHz
Noise Figure		dB	-	0.9	-	30MHz ~ 1000MHz
CSO	30 ~ 1000MHz	dBc	-	60	-	135 channel, +15dBmV/ch
CTB		dBc	-	70	-	135 channel, +15dBmV/ch
XMOD		dBc	-	80	-	135 channel, +15dBmV/ch
DC Current		mA	-	75	-	Vdd = 5.0V

### NOTE

1. Test conditions: Test Freq = 500MHz, T=25°C, Vdd=5V, 75Ω system

Application Circuit: 30MHz-1000MHz, 75ohm System

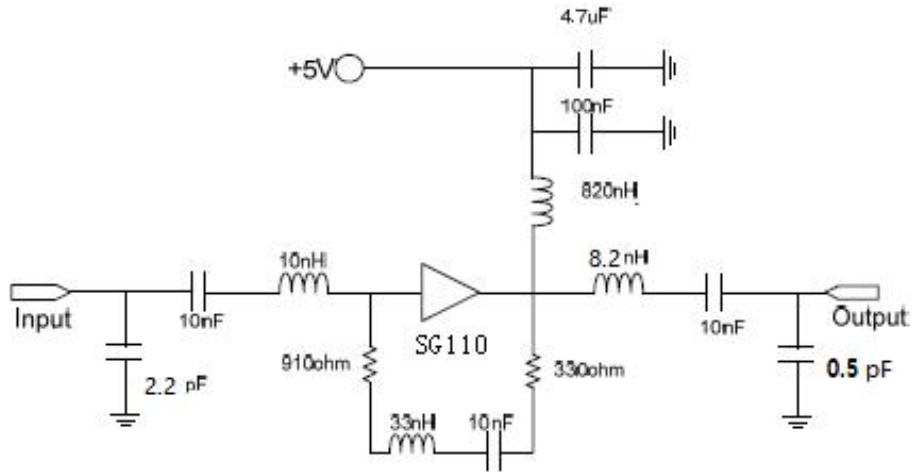

Typical RF Performance :  $V_{DD}=5V$ ,  $I_{DS}=75mA$ ,  $T=25^{\circ}C$ , 75ohm System

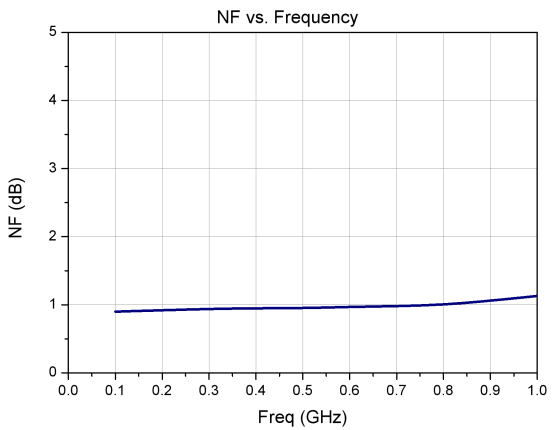
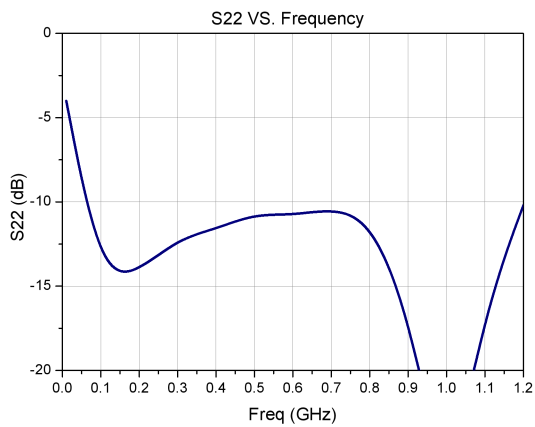
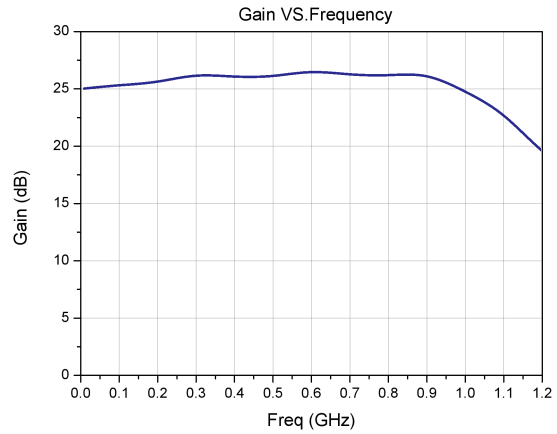
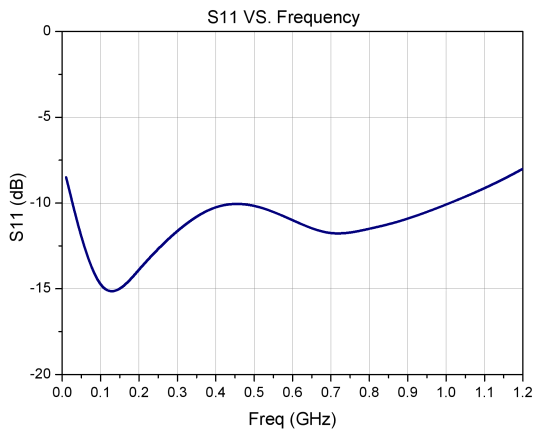

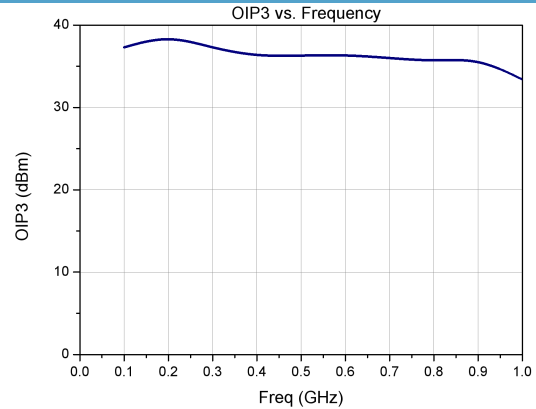
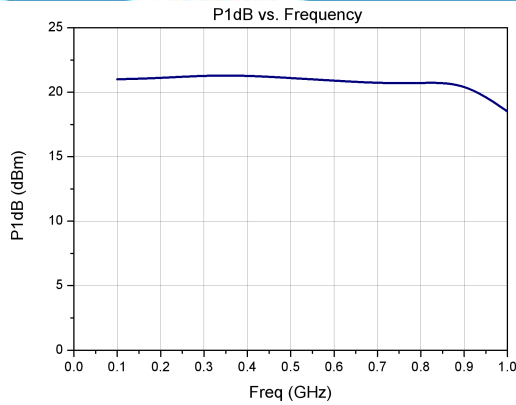

### PCB Mounting Information

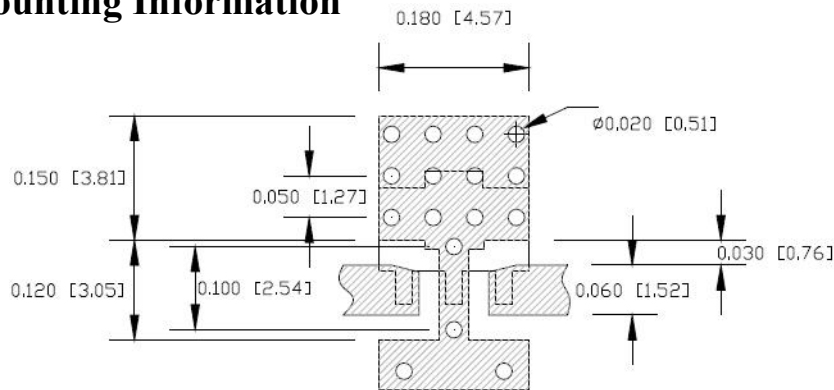

### Package Dimension

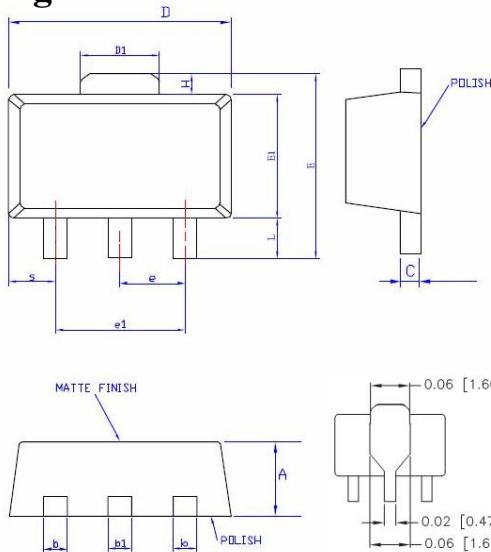

Units: inch [millimeter]

SYMBOLS	DIMENSIONS IN MILLIMETERS			DIMENSIONS IN INCHES		
	MIN	NOM	MAX	MIN	NOM	MAX
A	1.40	1.50	1.60	0.055	0.059	0.063
L	0.89	1.04	1.20	0.0350	0.041	0.047
b	0.36	0.42	0.48	0.014	0.016	0.018
b1	0.41	0.47	0.53	0.016	0.018	0.020
C	0.38	0.40	0.43	0.014	0.015	0.017
D	4.40	4.50	4.60	0.173	0.177	0.181
D1	1.40	1.60	1.75	0.055	0.062	0.069
E	3.94	—	4.25	0.155	—	0.167
E1	2.40	2.50	2.60	0.094	0.098	0.102
e1	2.90	3.00	3.10	0.114	0.118	0.122
H	0.35	0.40	0.45	0.014	0.016	0.018
S	0.65	0.75	0.85	0.026	0.030	0.034
e	1.40	1.50	1.60	0.054	0.059	0.063

For informational purpose only and is subject to change without notice

### NOTES:

1. Dimensions are in inch [millimeter].
2. Use 1 oz. copper minimum for top and bottom layer metal.
3. Vias are required under GND(2,4) pin for proper RF/DC grounding and thermal dissipation. Via holes could reduce lead inductance as close to ground as possible.
4. Ensure good package backside paddle solder attach for reliable operation and best electrical performance.