



Product Description:

The MDU RFoG series FTTB Node is mainly used for RFoG network. “OBI-Free” R-ONU eliminate the Optical Beat Interferences(OBI) that has been an issue in the traditional RFoG deployments. Its return path laser can work in burst or continuous mode. The upstream output optical wavelength can be set as CWDM standard wavelength to shield the OBI effectively.

Features:

- 1) Support downstream optical AGC, whose control range is -6~0dBm;
- 2) Adopt electrically adjustable mode for both EQ and ATT circuit, using LED displaying screen to modify directly;
- 3) Upstream output optical wavelength is optional(or specified by the user) .
- 4) Burst mode is supported;
- 5) OBI-Free technology on this model support up to 16 R-ONUs transmitting into a single optical input

Block Diagram:

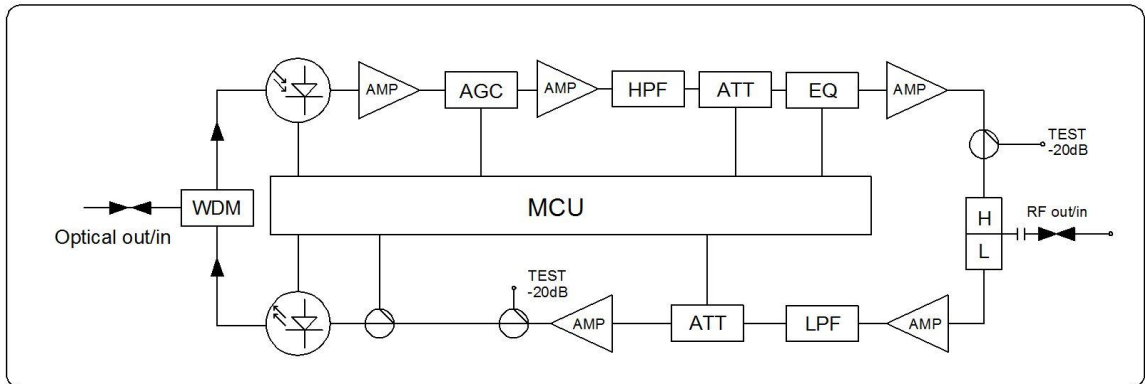

Characteristics:

(1) Downstream

No.	Item	Unit	Specification
Optical Specification			
1	Receiving Optical Power	dBm	-8~+2
2	Optical AGC Control Range	dBm	(default as-6~ 0)
3	Optical Return Loss	dB	>45
4	Optical Receiving Wavelength	nm	1100~1560
5	Optical Connector	-	SC/APC
6	Optical Fiber Type	-	Single mode
7	Laser Type	-	DFB laser

Link Performance				
1	RF Output level	dBuV	108	0dBm optical power input CENELEC 42 channels, EQ=6dB, Frequency=1218MHz
2	CTB	dBc	≥60	
3	CSO	dBc	≥60	
4	C/N	dBc	≥52	
RF Specification				
1	Frequency Range	MHz	54/87/110/258~1218	
2	RF Output Return Loss	dB	-16	
3	Flatness in Band	dB	+0.75@Pin=-3dBm	
4	Electrically adjustable equalizer	dB	0~10	
5	Equivalent Noise Current	-	<5, 5pA/rt(Hz)	
6	Output Impedance	Ω	75	
6	Electrically adjustable attenuator	dB	0~18	

(2) Upstream

No.	Item	Unit	Specification
Optical Specification			
1	Optical Transmitting Wavelength	nm	1610nm, can be adjusted in 0.2nm stepping or specified by the user
2	Output Optical Power	mW	3±1
3	Optical Connector	-	SC/APC
4	Maximum Delay from Monitoring RF Power onto Laser Optical Power on	uS	1.3
5	Maximum Time for Laser Output Optical Power from 10%to 90%	uS	1.0
6	Minimum Rise Time for Laser Output Optical Power from 10% to 90%	ns	100
7	Maximum Delay from Monitoring RF Power off to Laser Optical Power off	uS	1.6
8	Maximum Time for Laser Output Optical Power from 90% to 10%	us	1.0
9	Minimum Fall Time for Laser Output Optical Power from 90% to 10%	ns	100
RF Specification			
1	Frequency Range	MHz	5-42/65/85/204
2	Flatness in Band	dB	±0.75
3	Output Impedance	Ω	75
4	RF input Return Loss	dB	>16
5	NPR Dynamic Range	dB	>15@NPR>30
6	Electrically adjustable attenuator	dB	0-18
7	Laser on Level	dBuV	80±1
8	Laser off Level	dBuV	65±1

(3) General Specification

No.	Item	Unit	Specification
1	Power Voltage	V	AC(110~265)V
2	Protection Class	-	IP41
3	Operating Temperature	°C	-40~60
4	Storage Temperature	°C	-40~65
5	Relative Humidity	%	Maximum 95%(no-condensing)
6	Power Consumption	W	26
7	Dimension	mm	234(L)*140(W)*90.5(H)

Function Display and Operating Instruction

Open the R-ONU to set it. The following is the diagram of display tube and control button.

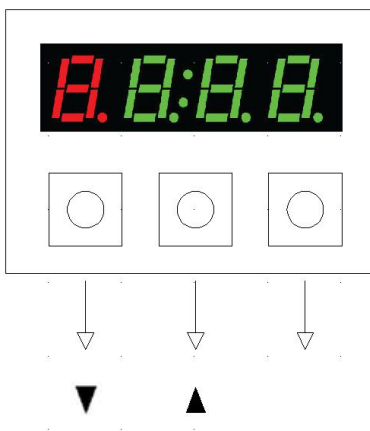

- “Mode” Key: Press this button to switch the working mode as the detailed description as below
- “▲” key: press this button to upward the working parameters.
- “▼” key: press this button downward the working parameters.

No	Item	Function
1	CNC display of working parameters with 4 digits	After start, the four digits quickly display the number 0-9 ,it help to check each digital tube is working or not. The first digit is red (displaying the menu mode), then the following three digits are green (display specific parameter values.)
2	Function Control Key	Mode
		▲
		▼
3	Working Mode	Working parameter switch key: switch the 6 working Mode.
		Upward Key : After entering each working parameter interface, press the key "▲" to upward the working parameters.
		Downward Key: After entering each working parameter interface, press the key "▼" to downward the working parameters.
3	Working Mode	The function of 4-digit display
		>>> Input Optical Power Display: when the first digit is "1" , which indicates the monitoring of forward input optical power , and the last three digits display the specific optical power value. If the optical power is too high(>2dBm) , "Hi" will be noticed; if too low(<-10dBm), then "Lo" is displayed; press the "mode"key to switch to next mode.
		>>> Downstream Attenuator Setting: when the first digit is "2" , which indicates the attenuation control of the forward output level. The last three digits display the specific attenuation value. The parameter can be adjusted by pressing the up and down keys with adjustment range being 0-18dB, and 1dB as one step. The value is originally set to be 0dB at factory. Parameters are automatically saved after adjustment. On this mode, press the "mode"key to switch to next mode.

		<p>>>> Equalizer adjustment: The first digit is “3”, which indicates the equalization control of the forward output level. The last three digits display the specific equalization value. The parameter can be adjusted by pressing the up and down keys with adjustment range being 0-10dB, and 1dB as one step. The value is originally set to be 4dB at factory. Parameters are automatically saved after adjustment. On this mode, press the “mode”key to switch to next mode.</p> <p>>>>Output optical wavelength setting: The first digit is “4”, which indicates the wavelength of reverse optical signal output is 1610nm. The wavelength can be adjusted by pressing up and down keys, and <u>0.2nm</u> as one step. The last three digits display the number between “1-16”, which indicates that 16 wavelengths can be set. Parameters are automatically saved after adjustment. On this mode, press the “mode”key to go back to first mode.</p> <p>>>> Upstream Attenuator Setting: The first digit is “5”, which indicates the attenuation control of the reverse output level. The last three digits display the specific attenuation value. The parameter can be adjusted by pressing the up and down keys with adjustment range being 0-18dB, and 1dB as one step. The value is originally set to be 0dB at factory.</p> <p>>>> Laser Operation Mode Setting: The first digit is “6”, which indicates the operation mode of Laser. The last three digits display the symbol “b” or “C”, which indicates that the laser is currently working in burst mode or continuous mode.</p>
--	--	---