

### Product Description:

The RFoG Mini Node is a small home optical node specially developed for cable TV operators using the DOCSIS protocol standard, to provide users with two-way, interactive TV and network services. Compared with other two-way optical nodes, this series of products has the characteristics of small size, flexible networking and high cost performance.



### FEATURES :

- 1) Designed for DOCSIS network
- 2) Forward 1550nm input power: -9~+3dBm, forward AGC Range: -6~+2dBm
- 3) Forward frequency: 54~1200MHz, EQ 3±1.5dB, RF output level: 73dBuV
- 4) Reverse 1610nm output Power: 2mW
- 5) Reverse frequency: 5~42MHz, RF input level: 75~112dBuV
- 6) LED on the housing for forward optical power, reverse optical power and 1V/ mW forward optical power
- 7) With -20dB RF output test port
- 8) Power consumption <3W
- 9) Compact Aluminium cast housing, perfect heat dissipation
- 10) Fully Compatible with SCTE Standards

### Block Diagram:

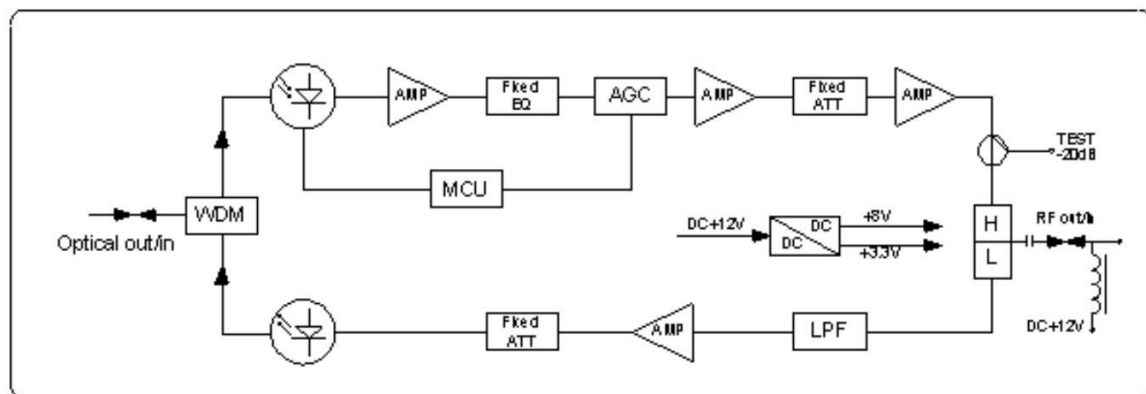

### Characteristics :

No.	Item	Unit	Specification
<b>Optical Specification</b>			
1	Receiving Wavelength	nm	1550 ± 10nm
2	Transmitting Wavelength	nm	1610 ± 10nm
<b>Forward Optical Specification</b>			
1	Wavelength	nm	1550 ± 10nm
2	Optical Power	dBm	-9 ~ +3
3	Optical AGC Range	dBm	-6 ~ +2
4	Optical LED		≥ +2dBm Red LED Flashing ≤ -6dBm Red LED on +2 ~ -6dBm Green LED on
<b>Forward RF Specification</b>			
1	Bandwidth	MHz	54 ~ 1200
2	Flatness	dB	≤ ±1
3	Return Loss	dB	≤ -14
4	Slope	dB	3 ± 1.5

5	Output Level	dBmV	13±1.5	@130MHz
6	C/N	dB	≥48	①@Pin=-5dBm
7	C/CTB	dB	≥65	②@Pin=0dBm
8	C/CSO	dB	≥62	③@Pin=0dBm
9	Output Impedance	Ω	75	
<b>Reverse Optical Specification</b>				
1	Wavelength	nm	1610±10nm	
2	Optical Output Power	mW	2.5±0.5mW	
3	Laser Type		DFB	
4	Laser Operation Mode		Burst Mode	
5	RF ON Threshold	dBmV	16±1.5	
6	RF OFF Threshold	dBmV	1±1.5	
7	Time Delay On	us	≤1.3	
8	Time Delay Off	us	≤1.6	
<b>ReverseRF Specification</b>				
1	Bandwidth	MHz	5–42	
2	Flatness	dB	≤±1	
3	Return Loss	dB	≤-14	
5	Input Level Range	dBuV	75–112	
6	NPR Dynamic Range	dB	20 (@NPR≥30dB)	
<b>Other Specification</b>				
1	Input Voltage of Power Adaptor	VAC	100–240	
2	Input Frequency of Power Adaptor	Hz	47–63	

3	Cabel Length of Power Adaptor	cm	—
3	Input Voltage of Device	VDC	12
4	Power Consumption	W	<3
5	Working Temperature	°C	-10—+50
6	Working Humidity	%RH	0—85
7	Fiber Connector		SC/APC
8	RF Connector		F-type imperial connector
9	Surge Protection	KV	4
10	Dimension (L*W*H)	mm	180×85×40

**Note:**

- ①、PAL-D 60 channels flat; measured at 543.25 MHz;Optical power receiving at -5dBm
- ②、PAL-D 60 channels flat; measured at 543.25 MHz;Optical power receiving at 0dBm
- ③、PAL-D 60 channels flat; measured at 543.25 MHz;Optical power receiving at 0dBm